

morphy richards®

**3 Year
Guarantee***

*Upon registering your product
at morphyrichards.co.uk

ILLUMINATION 4 Slice Toaster



Model No.
248020, 248021,
248022, 248023

User Manual

Please read and keep these instructions for future use

The use of any electrical appliance requires the following common sense safety rules.

Read these instructions carefully and retain for future reference.

- **WARNING:** Disconnect from the mains supply before carrying out any routine maintenance.
- **WARNING:** Misuse of the appliance could cause personal injury.
- This appliance can be used by children aged from 8 years and above and persons with reduced physical, sensory or mental capabilities, or lack of experience and knowledge, if they have been given supervision or instruction concerning the use of the appliance in a safe way and understand the hazards involved.
- Children shall not play with the appliance.
- Cleaning and user maintenance shall not be made by children unless they are older than 8 years and supervised.
- Keep the appliance and its cord out of reach of children less than 8 years.

- If the supply cable is damaged, it must be replaced by the manufacturer, its service agent or similarly qualified persons in order to avoid a hazard.
- The bread may burn, therefore do not use the appliance near or below combustible material such as curtains.
- This appliance is not intended to be operated on an extension cable or by means of an external timer or separate remote control system.
- This appliance is intended for household use only. It is not suitable for use in staff kitchen areas in shops, offices and other commercial environments.

WARNING: Danger to the person!

IMPORTANT: Damage to the appliance!

MAINS CABLE

- Do not let the cable run across a cooker or hot area which might damage the cable.

OTHER SAFETY CONSIDERATIONS

- Only use for intended purpose.

PERSONAL SAFETY

- Do watch your appliance during use.
- **WARNING:** Do not touch the top of the appliance or other hot parts during or after use, use handles or knobs.
- **WARNING:** Do not wrap the cable around the main body of the appliance during or after use.
- **WARNING:** Do not use under cupboards.
- **WARNING:** Do not insert oversize foods, metal, foil packages or utensils into the toaster.
- **WARNING:** Do not attempt to dislodge food when the appliance is plugged in and never insert cooking utensils into the slots.
- **IMPORTANT:** Do not place bread or other items on top of the slots as this may damage the appliance and creates a fire hazard.

PRECAUTIONS

- Never use the appliance when it is empty (when there is no bread inside) except on first use.
- Do not use very thin or broken slices of bread.
- Do not insert other foods that may drip during the cooking process. In addition to making the cleaning procedure more difficult, these may cause fires.
- Clean the crumb tray regularly: crumbs can smoke or burn.
- Do not insert (by force) foods that are too big for the slots.
- Do not insert forks or other utensils into the toaster in order to remove bread. As well as damaging the toaster, there is a high risk of electric shock.
- Should some toast remain blocked in the toaster, remove the plug from the mains, wait for the toaster to cool down until it is safe to touch, then turn the toaster over and shake it gently.

HEALTH AND SAFETY



**CAUTION!
HOT
SURFACE!**

**PLEASE BE AWARE OF HOT SURFACES
HANDLE WITH CARE**

Treating scalds

- Run cold water over the affected area immediately.
- Do not stop to remove clothing.
- Seek medical advice quickly.

ELECTRICAL DETAILS

- Check that the voltage on the rating plate of your appliance corresponds with your house electricity supply which must be A.C. (Alternating Current).
- Should the fuse in the mains plug require changing, replace it with a fuse of the same rating as originally fitted.
- The power consumption in off mode is 0W.
- When the appliance is not working, it enters the off mode immediately (0 min).
- **WARNING:** This appliance must be earthed.

PRODUCT OVERVIEW

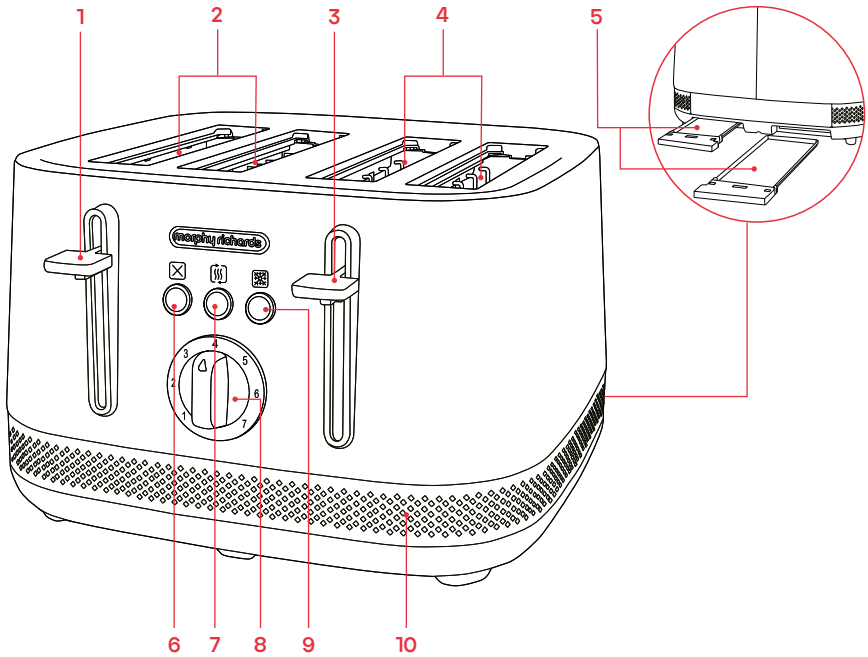

- | | |
|-------------------------------|------------------------|
| 1. Left Bread Carriage Lever | 6. Cancel Button |
| 2. Left Bread Slots | 7. Re-heat Button |
| 3. Right Bread Carriage Lever | 8. Browning Control |
| 4. Right Bread Slots | 9. Defrost Button |
| 5. Crumb Trays (at rear) | 10. Illumination Strip |

BEFORE FIRST USE

Before using the appliance for the first time, operate the toaster without bread.

As with all new electric heating elements, your toaster will emit a 'new' smell when it is first switched on. This is quite normal and not a cause for concern.

QUICK START GUIDE

If toasting one
or two slices:

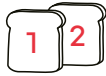

Always use
the left bread
carriage lever (1)
and left bread
slots (2)

If toasting more
than two slices:



Use both the Left (1)
and right (3) bread
carriage levers and
left (2) and right (4)
bread slots

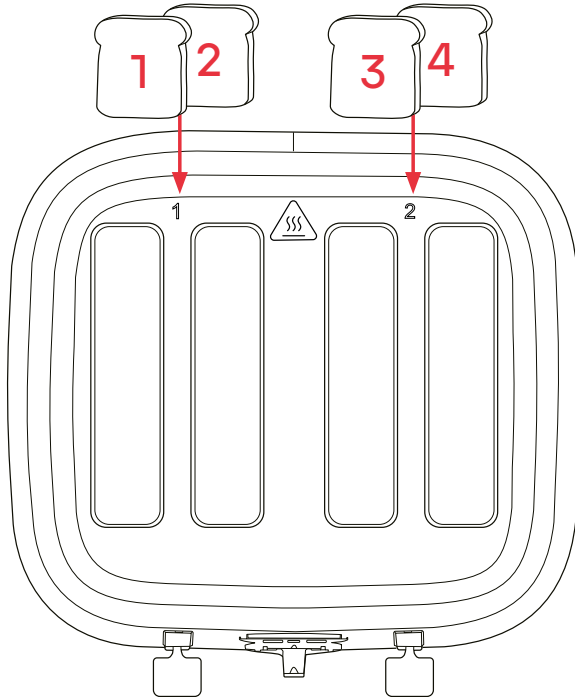

The right bread carriage lever (3) will not operate unless the left bread carriage lever (1) is in use.

TOASTING ONE OR TWO SLICES

Place the sliced bread into the left bread slots (2).

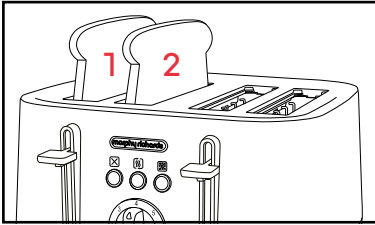

Adjust the browning control (8) to the desired setting.

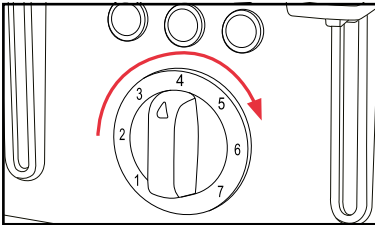

Depress the left bread carriage lever (1). The toaster will begin toasting the bread. The illumination strip (10) and the cancel button (6) will light up.

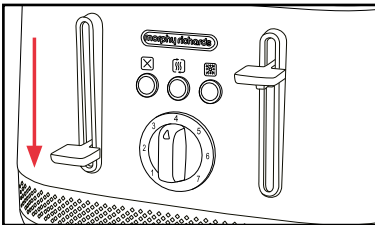

When completed, the left bread carriage lever will automatically rise and lift the toast from the toaster.

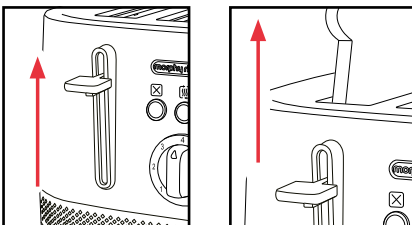

TOASTING THREE OR FOUR SLICES

Place the sliced bread into the left (2) and right (4) bread slots.

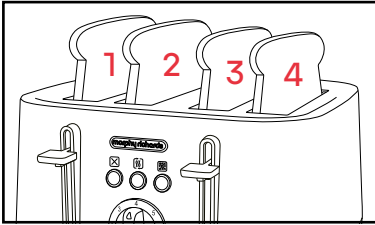

Adjust the browning control (8) to the desired setting.

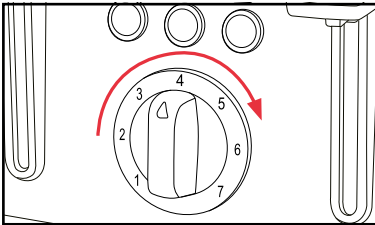

Depress both bread carriage levers (1 & 3). The toaster will begin toasting the bread. The illumination strip (10) and the cancel button (6) will light up.

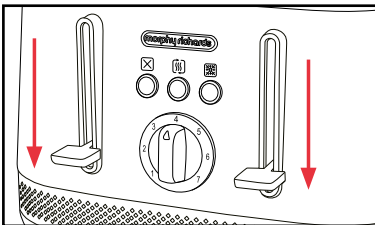

When completed, the bread carriage levers will automatically rise and lift the toast from the toaster.

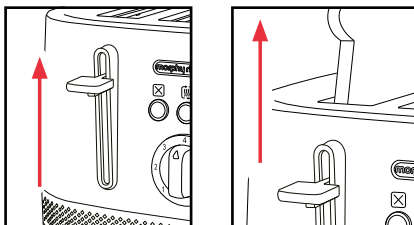

ADDITIONAL FEATURES

Cancel Button (6)

If you wish to stop the toasting process, press the cancel button.

Re-heat Button (7)

If your toast has popped up and gone cold, the toaster offers a re-heat facility. To use, lower the bread carriage levers (1 & 3) and press the re-heat button immediately. The button will illuminate and the toaster will operate for a short period reheating the bread.

Defrost Button (9)

To toast frozen bread, do not adjust the browning controls (8) from your normal setting. Place the frozen bread in the bread slots (2 & 4), lower the bread carriage lever and press the defrost button. The button will illuminate and the toaster will operate for a longer period defrosting and toasting the bread.

HINTS AND TIPS

- In order to achieve uniform browning, we recommend you wait a minimum of 30 seconds between each toasting cycle, so that the control can be automatically reset.
- **If toasting one slice only, you may need to adjust the browning control (8) to a slightly lower setting. You will notice a variation in toast colour on one side of a single slice. The side next to the empty slot that is powered on will usually be darker due to the extra heat.**
- When toasting 2 slices it is recommended they are of equal size and freshness.
- Stale bread toasts more rapidly than fresh bread. Therefore, the browning controls should be set at a lower setting than usual.
- All sorts of bread can be used as well as teacakes, small rolls etc. However, slices should not be so thick they will cause burning or jamming within the bread slots (2 & 4).
- If the bread in your toaster becomes jammed disconnect your toaster at the socket, allow it to cool, then remove the bread.
- Allow your toaster to cool fully before storing.

CLEANING YOUR TOASTER

- Before cleaning, unplug your toaster and let it cool fully.
- The external surfaces of your toaster can be cleaned with a soft cloth. Do not use abrasive detergents that can ruin the surface.
- **DO NOT IMMERSE IN WATER.**
- After each use, remove the plug from the electrical outlet and empty the crumb collection tray that is under the appliance.
- **DO NOT TOUCH ANY PART OF YOUR TOASTER WITH SHARP OR METAL UTENSILS, ESPECIALLY INSIDE THE BREAD SLOTS. RISK OF ELECTRIC SHOCK AND DAMAGE TO THE TOASTER.**

REMOVEABLE CRUMB TRAYS (5)

WARNING: Crumbs will accumulate in the crumb trays and could catch fire if not emptied regularly.

1. When your toaster has cooled down completely, tap the sides of the case lightly to dislodge any crumbs lodged in the bread slots (2 & 4).
2. Pull the crumb trays and remove from the toaster.
3. Empty the crumb trays and replace back into the toaster.

Never operate your toaster without the crumb trays fitted.

TROUBLESHOOTING

Problem	Solution
No power	Try another socket.
	Change the fuse in the plug.
Bread carriage levers won't latch	Ensure the toaster is plugged in and switched on at the mains outlet.
Bread is burnt	Check the bread isn't too thick and touching the elements.
	Ensure the correct setting is selected on the browning control and change as necessary
Smoking	Check that the bread isn't touching the elements. Replace with thinner slices.
	Check the crumb tray isn't full. Empty as necessary.

CONTACT US

If you are having a problem with your appliance, please contact our Helpline, as we are more likely to be able to help than the store you purchased the item from. Please have the product name, model number and serial number to hand when you contact us to help us deal with your enquiry quicker.

email: hello@morphyrichards.co.uk

www.morphyrichards.co.uk

PRODUCT RECYCLING



For electrical products sold within the European Community, at the end of the electrical products useful life, it should not be disposed of with household waste.

Please recycle where facilities exist.

Check with your Local Authority or retailer for recycling advice in your country.

REGISTERING YOUR 3 YEAR GUARANTEE

Your standard 2 year guarantee is extended for an additional 1 year when you register the product within 28 days of purchase with Morphy Richards. If you do not register the product with Morphy Richards within 28 days, your product is guaranteed for 2 years.



To validate your 3 year guarantee,
scan the QR code or register online
at www.morphyrichards.co.uk

N.B. Each qualifying product needs to be registered with Morphy Richards individually. Please note that the 2 year guarantee is only available in the UK. Please refer to the 2 year guarantee for more information.

YOUR 2 YEAR GUARANTEE

It is important to retain the retailer's receipt as proof of purchase. Staple your receipt to the back cover for future reference.

Please quote the following information if the product develops a fault. These numbers can be found on the base of the product.

Model no.

Serial no.

All Morphy Richards products are individually tested before leaving the factory. In the unlikely event of any appliance proving to be faulty within 28 days of purchase, it should be returned to the place of purchase for it to be replaced. If the fault develops after 28 days and within 24 months of original purchase, you should contact the Helpline quoting Model number and Serial number on the product, or write to Morphy Richards at the address shown. You may be asked to return a copy of proof of purchase.

Subject to the exclusions set out on the next page (see Exclusions), the faulty appliance will then be repaired or replaced as appropriate and dispatched usually within 7 working days of receipt.

If, for any reason, this item is replaced or repaired during the 2 year

REGISTERING YOUR 3 YEAR GUARANTEE

guarantee period, the guarantee on the new item will be calculated from the original purchase date. Therefore it is vital to retain your original till receipt or invoice to indicate the date of initial purchase.

To qualify for the 2 year guarantee, the appliance must have been used according to the instructions supplied.

The appliance is intended for domestic use only. Misuse or use for commercial or any other purpose will render the guarantee invalid.

Exclusions

Morphy Richards shall not be liable to replace or repair the goods under the terms of the guarantee where:

1. The fault has been caused or is attributable to accidental use, misuse, negligent use or used contrary to the manufacturer's recommendations or where the fault has been caused by power surges or damage caused in transit.
2. The appliance has been used on a voltage supply other than that stamped on the products.
3. Repairs have been attempted by persons other than our service staff (or authorised dealer).
4. The appliance has been used for hire purposes or non domestic use.
5. The appliance is second hand or refurbished.
6. Morphy Richards reserves the right not to carry out any type of servicing under the guarantee at its discretion.

This guarantee does not confer any rights other than those expressly set out above and does not cover any claims for consequential loss or damage. This guarantee is offered as an additional benefit and does not affect your statutory rights as a consumer. Morphy Richards products are intended for household use only. See usage limitations within the location safety instructions.

Disclaimer

Morphy Richards has a policy of continuous improvement in product quality and design. The company, therefore reserves the right to change the specification of its models at any time.

morphy richards®



@morphyrichardsuk #loveyourmorphy

[morphyrichards.co.uk](https://www.morphyrichards.co.uk)

Morphy Richards

9 Cabot Lane, Poole, Dorset, BH17 7BY, UK

